

**Elévation Ech: 1/10**

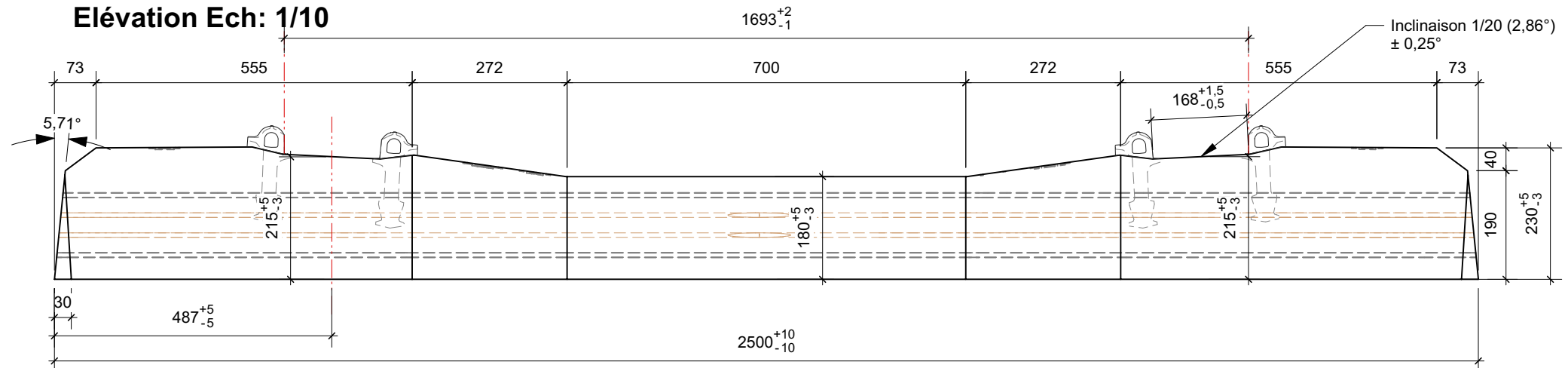

**Vue de gauche Ech: 1/10**

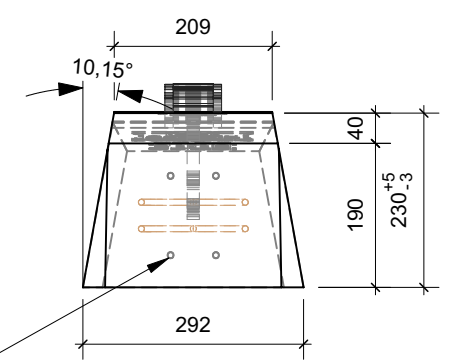

**Vue en plan Ech: 1/10**

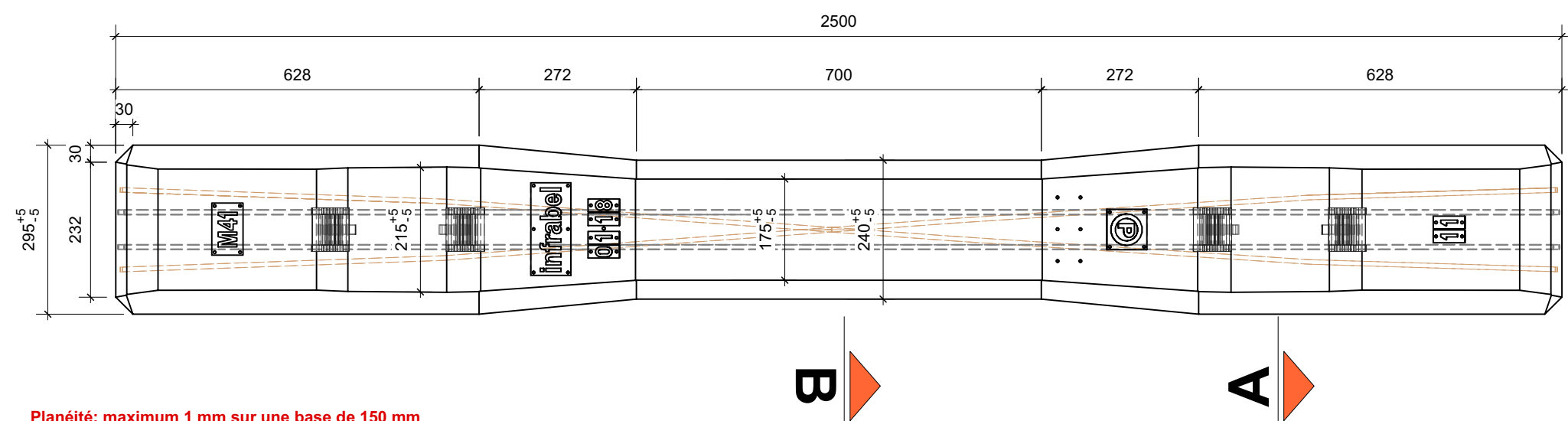

8x8mm FILS PROFILES  
ST 1470/1670  
NBN I 10-002. I 10-003

**Coupe AA Ech: 1/10**

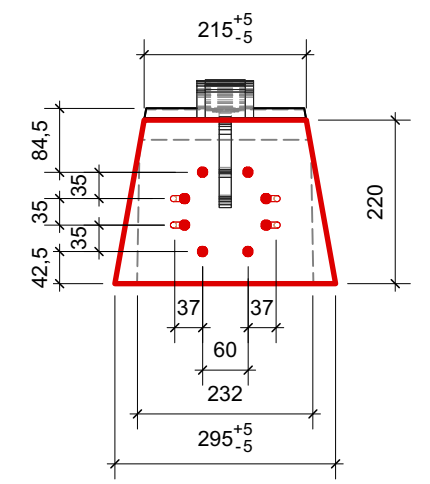

**Coupe BB Ech: 1/10**

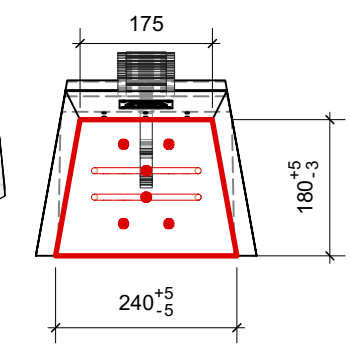

Planéité: maximum 1 mm sur une base de 150 mm  
Torsion relative entre les tables d'appuis des rails: maximum 0,5°

C ( 0,40 : 1 ) Epaulements (NBN EN 1563)  
6522 Pandrol

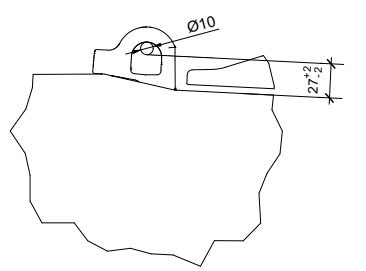

FORCE DE PRECONTRAINTÉ: 523 kN · 10kN

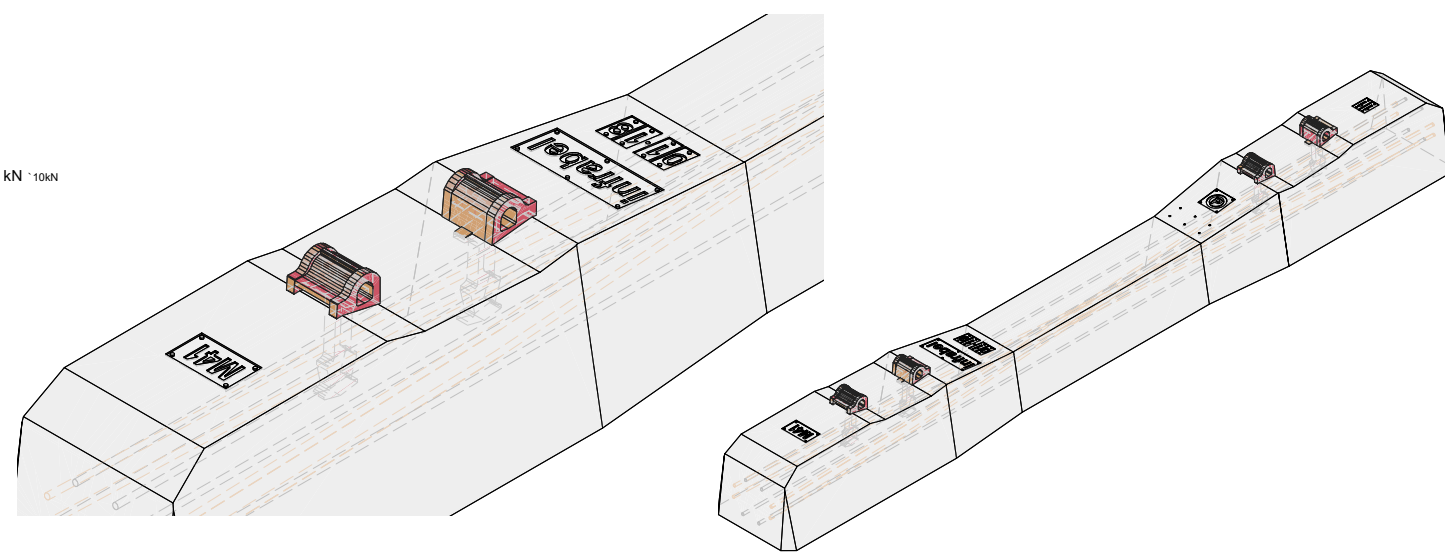

**prefer** 

Rue de la Digue 20  
4400 FLÉMALLE  
Belgique

Tél. : +32 (0)4/234.83.40  
Fax : +32 (0)4/234.83.21  
E-mail : info@prefer.be

<b>CLIENT :</b>	
<b>PROJET :</b>	Traverses type M41
Adresse :	
Plans de réf. :	Indice :

15/10/2018	INDICE : <b>G</b>
C 18/02/13	Modification poids
D 19/02/13	Modif svt plan ptec
E 14/03/13	Ajout douilles fixation
F 08/04/13	Ajustement cotations
G 15/10/18	Ajout marquages & épaulements

<b>Plan n°:</b>	
<b>BETON</b>	
TEINTE	RECETTE

<b>TYPE DE PIÈCE</b>	Traverse M41 (SNCB) 2500/292/232
<b>QUANTITÉ</b>	1 pc
Volume :	0,12 m3
Poids :	310 ±15 Kg
Ce plan est notre propriété et ne peut être reproduit ou communiqué à des tiers sans notre autorisation écrite.	
Copyright © PREFER 2018	

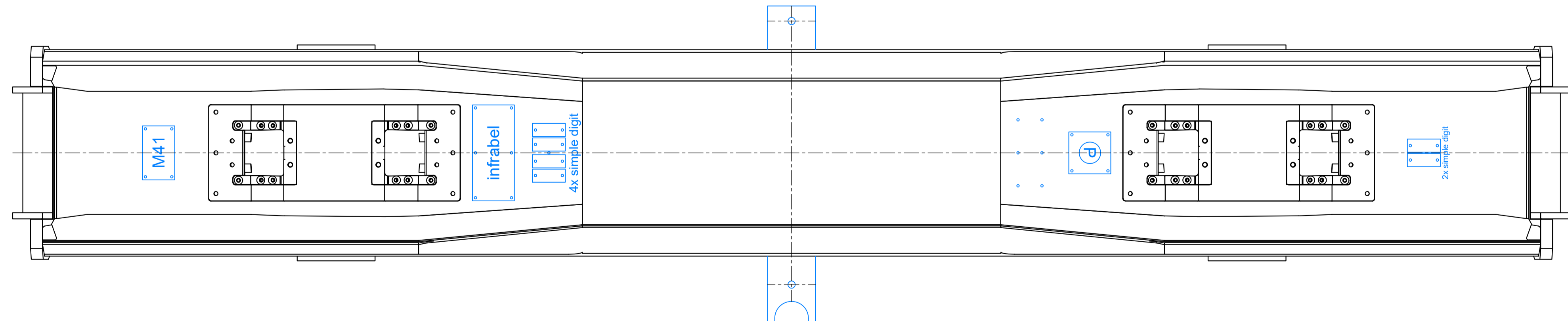
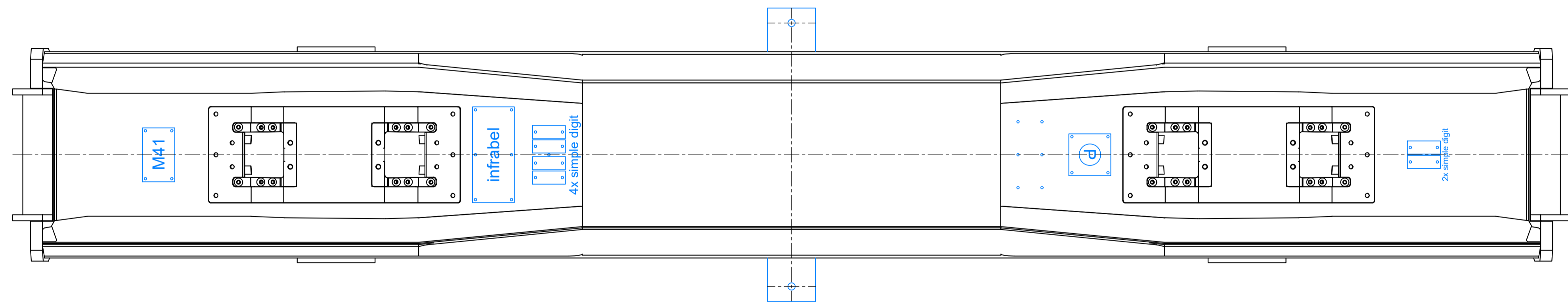
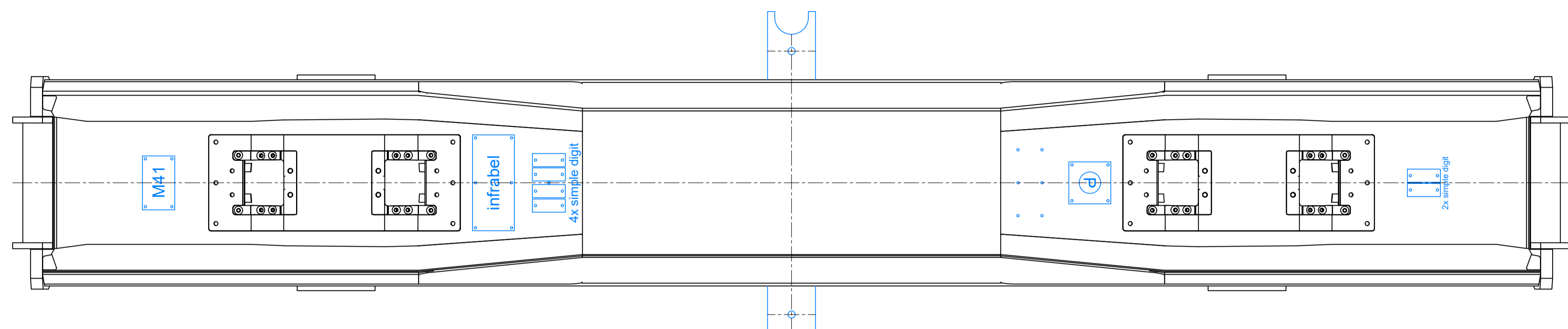
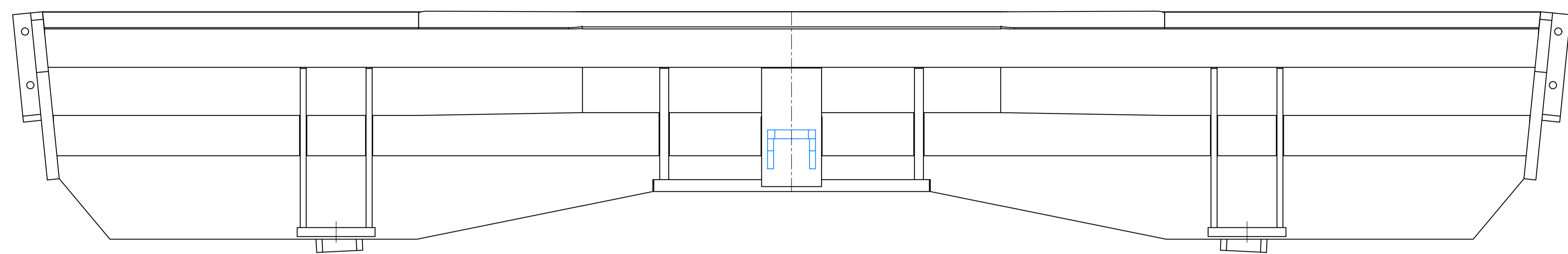

Moule type 1  
6x

Moule type 2  
6x

Moule type 3  
6x  
(5+1 prototype)

A T T E L I E R S			
M E L E N S & D E J A R D I N <small>SPRL</small>			
RUE D. SIMONIS, 55 - 4020 JUPILLE SIM		Tél. +32(0)4 362 62 20 Fax +32(0)4 362 04 58	
AFFAIRE <b>Prefer - 18 moules traverse M41</b>		N° DOSSIER / N° PLAN <b>1806-003-A</b>	
OBJET DU PLAN <b>Répartition des supports et lettrages</b>			
INDICE	DATE	DESSINE	MODIFICATION
A	05-04-2018	Serruys P.	Bon pour exécution
ECHELLE:	1/5	DATE:	05-04-2018
		DESSINE PAR:	Serruys P.